

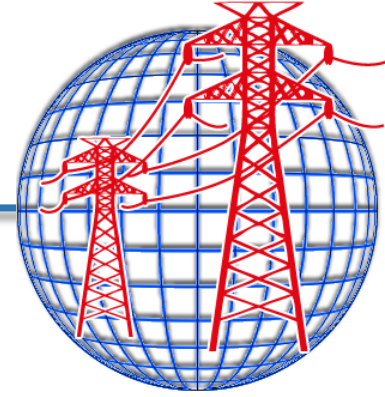

**BIRZEIT UNIVERSITY  
FACULTY OF ENGINEERING  
AND TECHNOLOGY**



**PROTECTION AND AUTOMATION IN ELECTRICAL POWER SYSTEMS**

By

**Dr. Jaser Sa'ed**

Department of Electrical and Computer Engineering



# INTRODUCTION

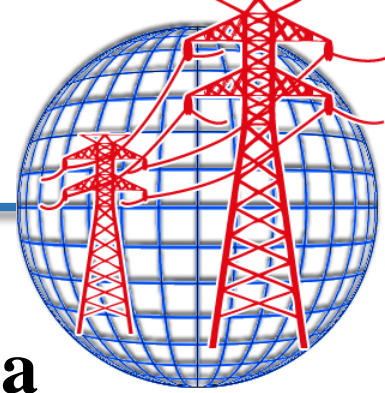

**A primary objective of all power systems is to maintain a very high level of continuity of service, and when intolerable conditions occur, to minimize the extent and time of the outage.**



**It is impossible, as well as impractical, to avoid the consequences of natural events, physical accidents, equipment failure, or mis-operation owing to human error; many of these result in faults**

# INTRODUCTION - FAULTS

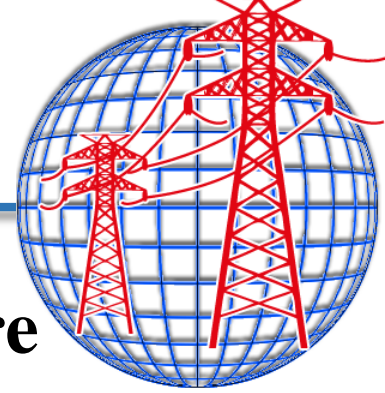

**Natural events that can cause short circuits (faults) are lightning, wind, ice, earthquake, fire, explosions, falling trees, flying objects, physical contact by animals, and contamination.**



**Accidents include faults resulting from vehicles hitting poles or contacting live equipment, unfortunate people contacting live equipment, digging into underground cables, human errors, and so on.**



**Considerable effort is made to minimize damage possibilities, but the elimination of all such problems is not yet achievable.**

# INTRODUCTION - FAULTS

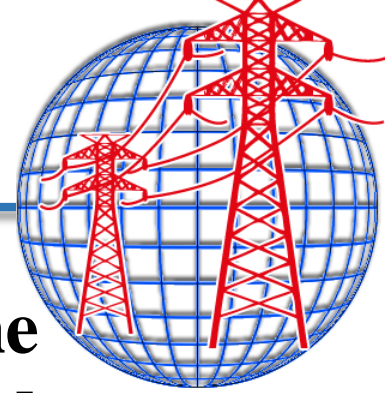

**Fault occurrence can be quite variable, depending on the type of power system (e.g., overhead vs. underground lines) and the local natural or weather conditions.**



**The faults include the following, with very approximate percentages of occurrence:**

- **Single phase-to-ground: 70%–80%**
- **Phase-to-phase-to ground: 17%–10%**
- **Phase-to-phase: 10%–8%**
- **Three-phase: 3%–2%**

# INTRODUCTION - FAULTS

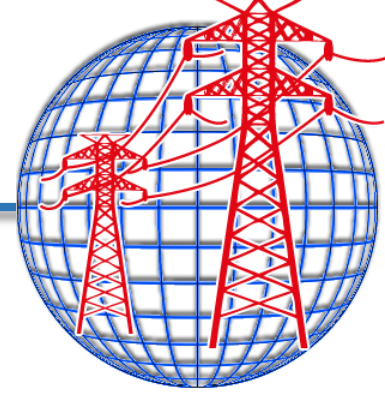

## Faults can damage or disrupt power system in several ways

- ❑ Faults typically allow abnormally large currents to flow, resulting in overheating of power system components.
- ❑ The fault is usually a short circuit and exists as an electrical arc; the extremely high temperatures in arcs will cause equipment destruction and fire .
- ❑ Faults can lower, or raise, system voltages outside of their acceptable ranges.
- ❑ Faults can cause the three phase system to become unbalanced; causing three phase equipment to operate improperly.
- ❑ Faults block the flow of power.
- ❑ Faults can cause the system to become unstable, and “break-up” (i.e., lose synchronism)

# INTRODUCTION - FAULTS

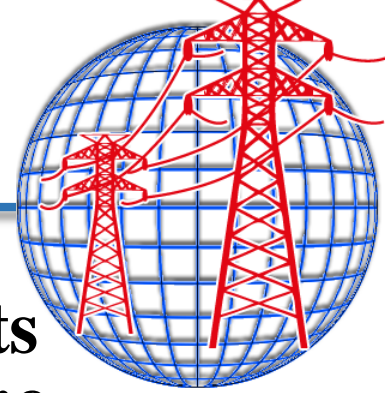

**In many instances the flashover caused by such events mentioned earlier does not result in permanent damage if the circuit is interrupted quickly. A common practice is to open the faulted circuit, permit the arc to extinguish naturally, and then close the circuit again. Usually, this enhances the continuity of services by causing only a momentary outage and voltage dip. Typical outage times are in the order of 0.5 to 1 or 2 min, rather than many minutes and hours!**

# INTRODUCTION - FAULTS

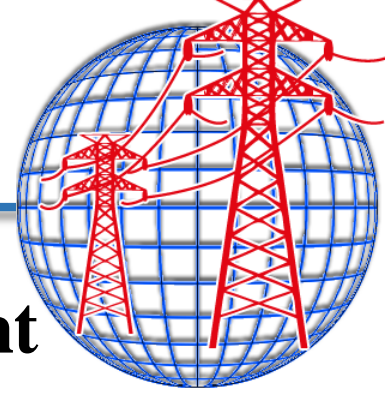

**System faults usually, but not always, provide significant changes in the system quantities, which can be used to distinguish between tolerable and intolerable system conditions. These changing quantities include overcurrent, over- or under-voltage power, power factor or phase angle, power or current direction, impedance, frequency, temperature, physical movements, pressure, and contamination of the insulating quantities. The most common fault indicator is a sudden and generally significant increase in the current; consequently, overcurrent protection is widely used.**



# INTRODUCTION – PROTECTION SYSTEM

---

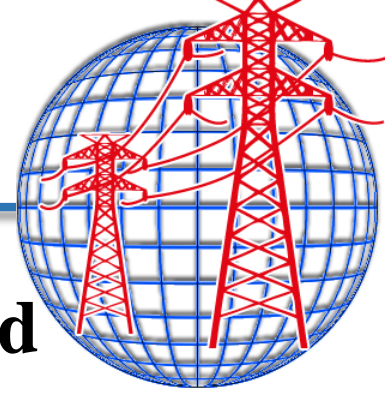

**Protection is the science, skill, and art of applying and setting of protection devices , to provide maximum sensitivity to faults and undesirable conditions, but to avoid their operation under all permissible or tolerable conditions.**

Objectives ...



# INTRODUCTION – PROTECTION SYSTEM

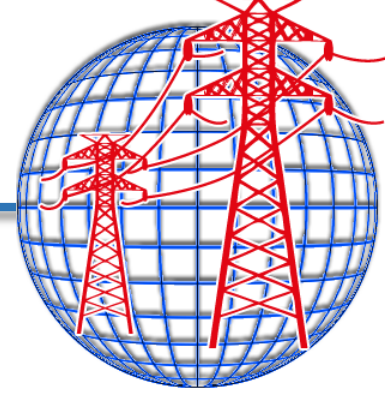

**It is important to state the objectives of power system protection schemes. Ideally, a protection scheme should:**

- ❑ Detect and isolate faults instantaneously at any point in the system.**
- ❑ Accomplish the above, keeping as much of the system interconnected as possible.**
- ❑ Since many faults are self-clearing, restore the system to its original configuration as soon as possible.**
- ❑ Clearly discriminate between normal and abnormal system conditions so that protection devices never operate unnecessarily.**

# INTRODUCTION – PROTECTION SYSTEM

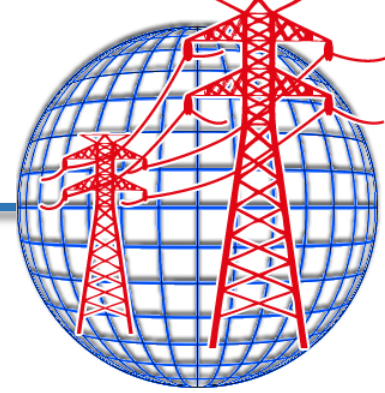

System protection components have the following design criteria:

- ❑ **Selectivity**: To detect and isolate the faulty item only, avoid unnecessary false trips.
- ❑ **Sensitivity**: To detect even the smallest fault, current or system abnormalities and operate correctly at its setting.
- ❑ **Speed**: Operate rapidly to minimize fault duration and equipment damage, and to ensure safety to personnel. Any intentional time delays should be precise.
- ❑ **Reliability**: Operate dependably when fault conditions occur, even after remaining idle for months or years. Failure to do so may result in costly damages. (Dependability, Security)
- ❑ **Economy**: Provide maximum protection at minimum cost.
- ❑ **Simplicity**: Minimize protection equipment and circuitry.

# SYSTEM PROTECTION – BASIC COMPONENTS

---

- ❑ **Instrument Transformers, System Transducers, Voltage Transformers (VT or PT) and current transformers (CT):** To monitor and give accurate feedback about the healthiness of a system.
- ❑ **Relays:** To convert the signals from the monitoring devices, and give instructions to open a circuit under faulty conditions and to give alarms when the equipment being protected.
- ❑ **Fuses:** Self-destructing to save the downstream equipment being protected.
- ❑ **Circuit breakers:** These are used to make circuits carrying enormous currents, and also to break the circuit carrying the fault currents for a few cycles based on feedback from the relays.
- ❑ **Recloser:** self-controlled devices for automatically interrupting and reclosing a circuit with a predetermined sequence of opening and reclosing.
- ❑ **DC batteries:** These give uninterrupted power source to the relays and breakers that is independent of the main power source being protected.

# OVERCURRENT PROTECTION SCHEMATIC, EXAMPLE

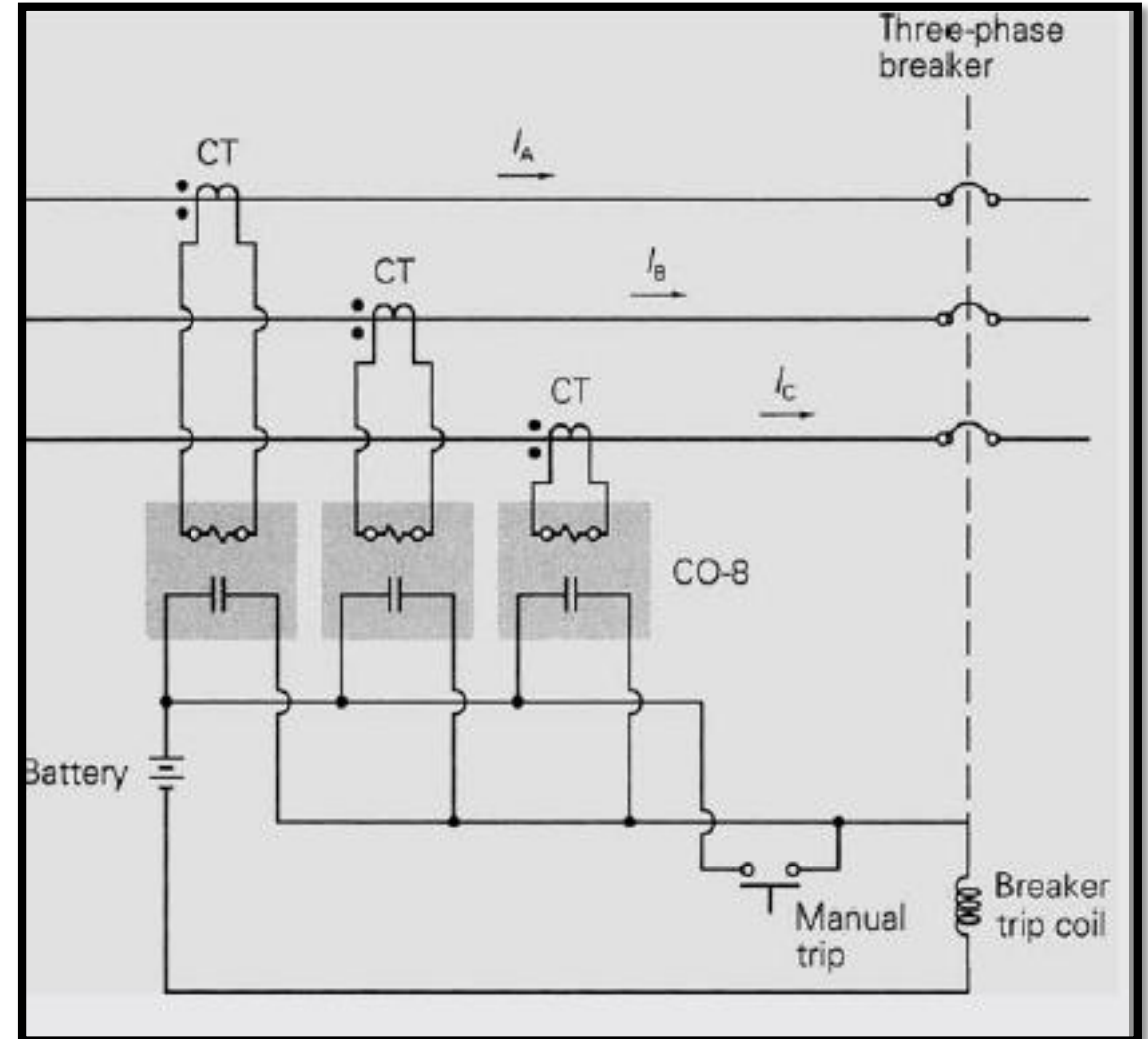
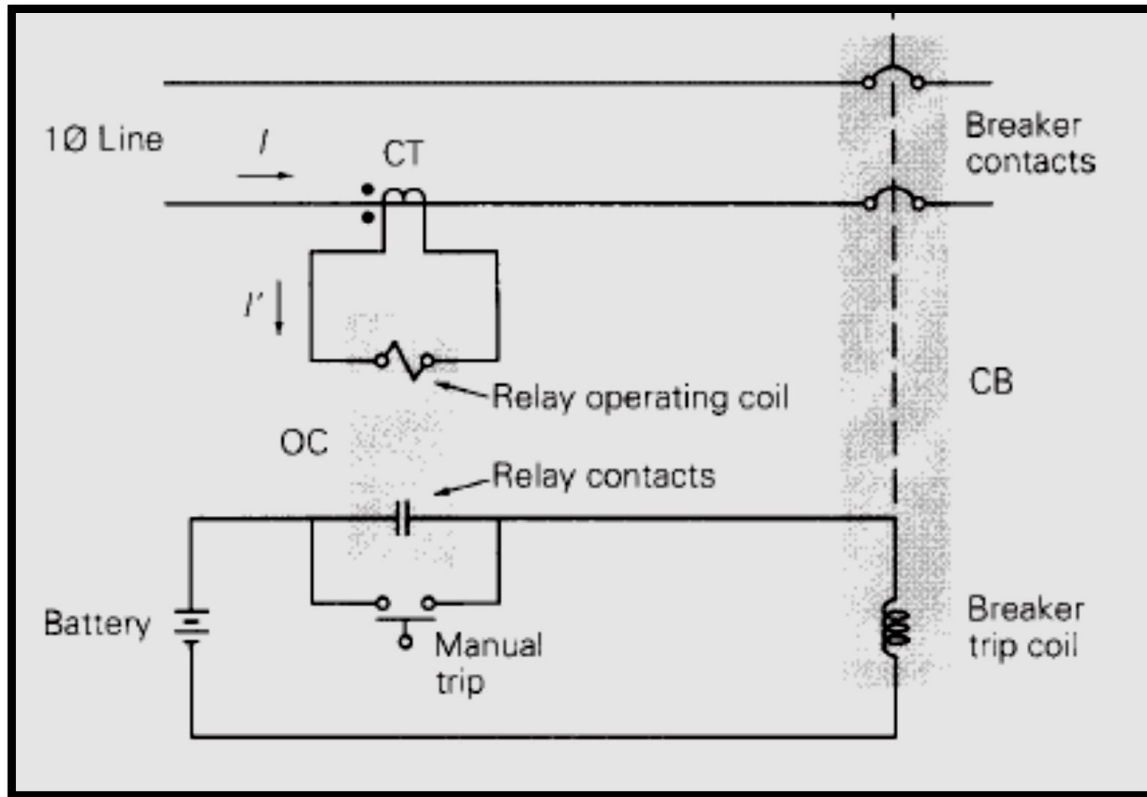

# PROTECTION SCHEMATIC, EXAMPLE

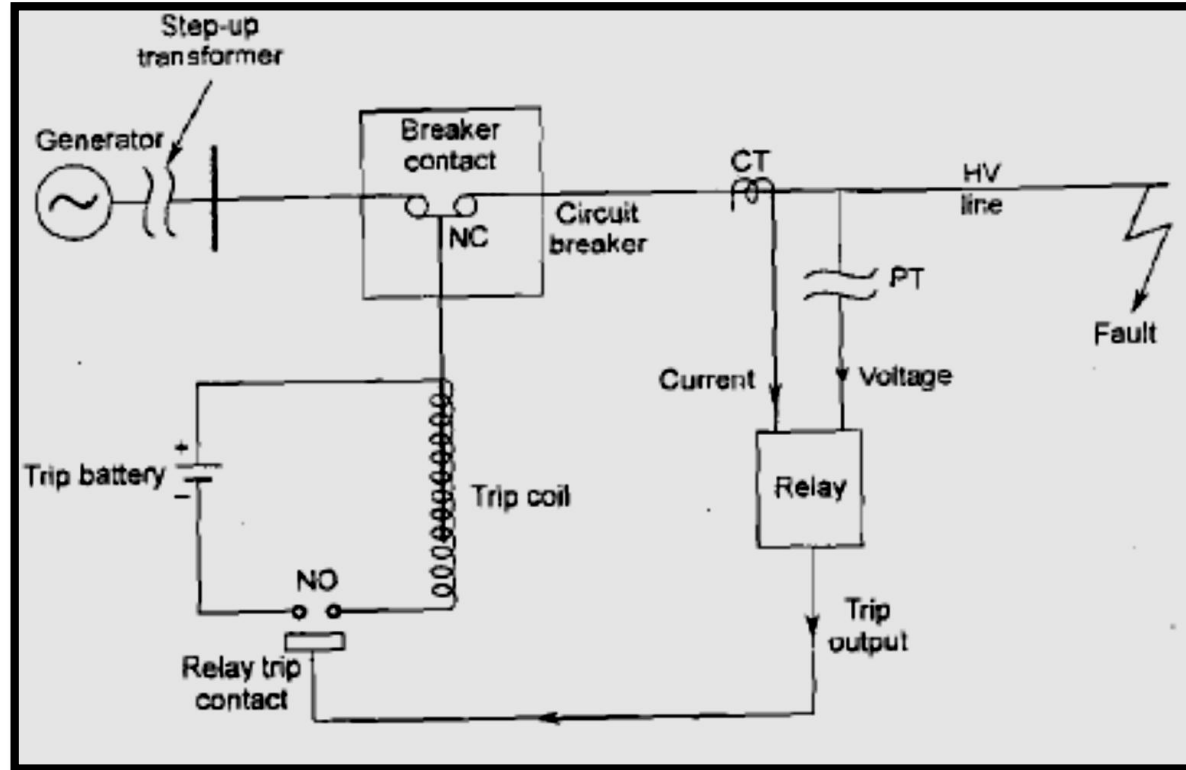

# OVERCURRENT PROTECTION SCHEMATIC, EXAMPLE

- ❑ The function of the CT is to reproduce in its secondary winding a current  $I'$  that is proportional to the primary current  $I$ . The CT converts primary currents in the kiloamp range to secondary currents in the 0–5 ampere range.
- ❑ The function of the relay is to discriminate between normal operation and fault conditions. The OC relay in previous figure has an operating coil, which is connected to the CT secondary winding, and a set of contacts.
- ❑ When  $|I'|$  exceeds a specified “pickup” value, the operating coil causes the normally open contacts to close. When the relay contacts close, the trip coil of the circuit breaker is energized, which then causes the circuit breaker to open.
- ❑ Note that the circuit breaker does not open until its operating coil is energized, either manually or by relay operation. Based on information from instrument transformers, a decision is made and “relayed” to the trip coil of the breaker, which actually opens the power circuit—hence the name relay.
- ❑ The relays for each breaker are connected as shown, so that all three phases of the breaker open when a fault is detected on any phase.

# DEFINITIONS USED IN SYSTEM PROTECTION

- **Protective relaying** is the term used to signify the science as well as the operation of protective devices, within a controlled strategy, to maximize service continuity and minimize damage to property and personnel due to system abnormal behavior. The strategy is not so much that of protecting the equipment from faults, as this is a design function, but rather to protect the normal system and environment from the effect of a system component which has become faulted.
- **Protection zones** (primary protection zones) are regions of primary sensitivity. The Figure shows a small segment of a power system with protection zones enclosed by dashed lines.

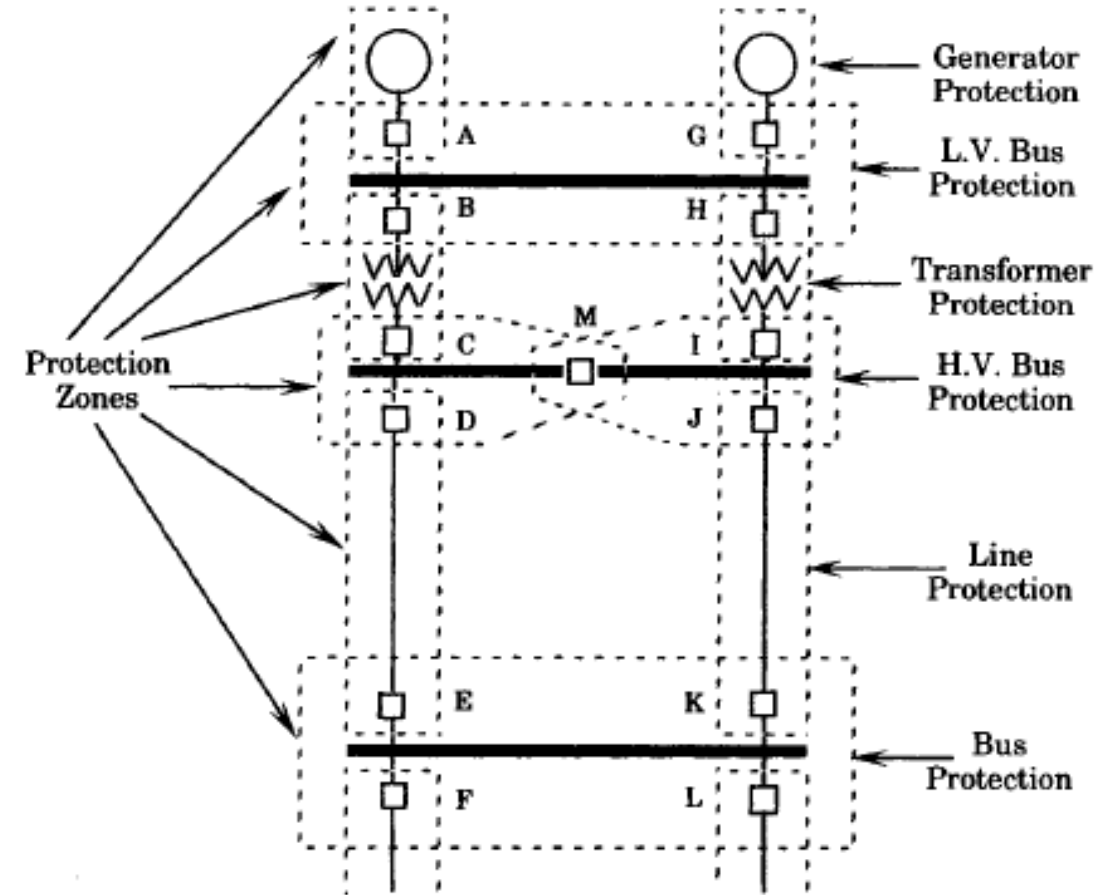



# DEFINITIONS USED IN SYSTEM PROTECTION

---

- ❑ **Sensitivity** in protective systems is the ability of the system to identify an abnormal condition that exceeds a nominal "pickup" or detection threshold value and which initiates protective action when the sensed quantities exceed that threshold.
- ❑ **Coordination** of protective devices is the determination of graded settings to achieve selectivity.
- ❑ **Selectivity** in a protective system refers to the overall design of protective strategy wherein only those protective devices closest to a fault will operate to remove the faulted component. This implies a grading of protective device threshold, timing, or operating characteristics to obtain the desired selective operation. This restricts interruptions to only those components that are faulted.

# DEFINITIONS USED IN SYSTEM PROTECTION

- **Primary relays** (primary sensitivity) are relays within a given protection zone that should operate for prescribed abnormalities within that zone. In Figure, for example, consider a fault on line JK. For this condition, relays supervising breakers J and K should trip before any others and these relays are called primary relays.

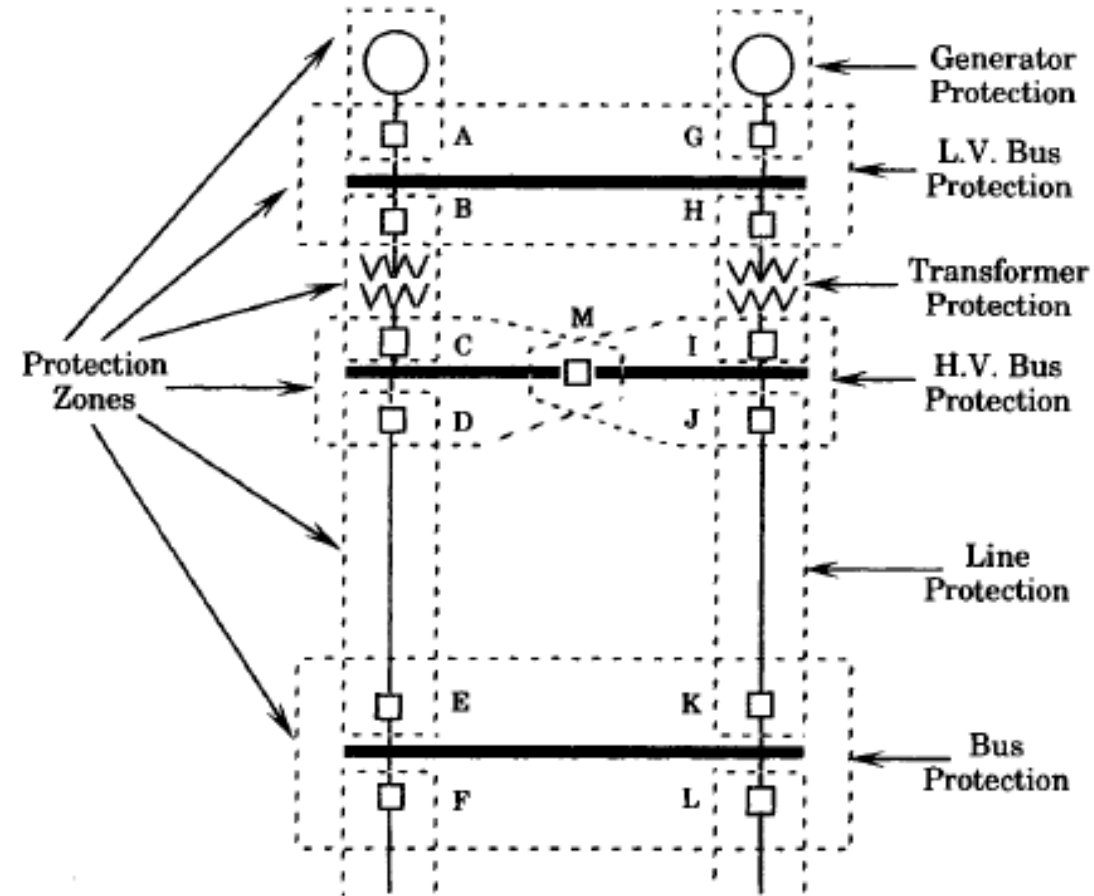

# DEFINITIONS USED IN SYSTEM PROTECTION

- **Backup relays** are relays outside a given primary protection zone, located in an adjacent zone, which are set to operate for prescribed abnormalities within the given primary protection zone and independently of the primary relays. For example, suppose a fault on line JK of Figure shown cannot be cleared by breaker J due to relay or breaker J malfunction. Assume that breaker K operates normally leaving the fault connected to the bus terminated by breakers IJM. Backup relays at locations I and M should be set to operate for the fault on line JK, but only after a suitable delay that would allow breaker J to open first.

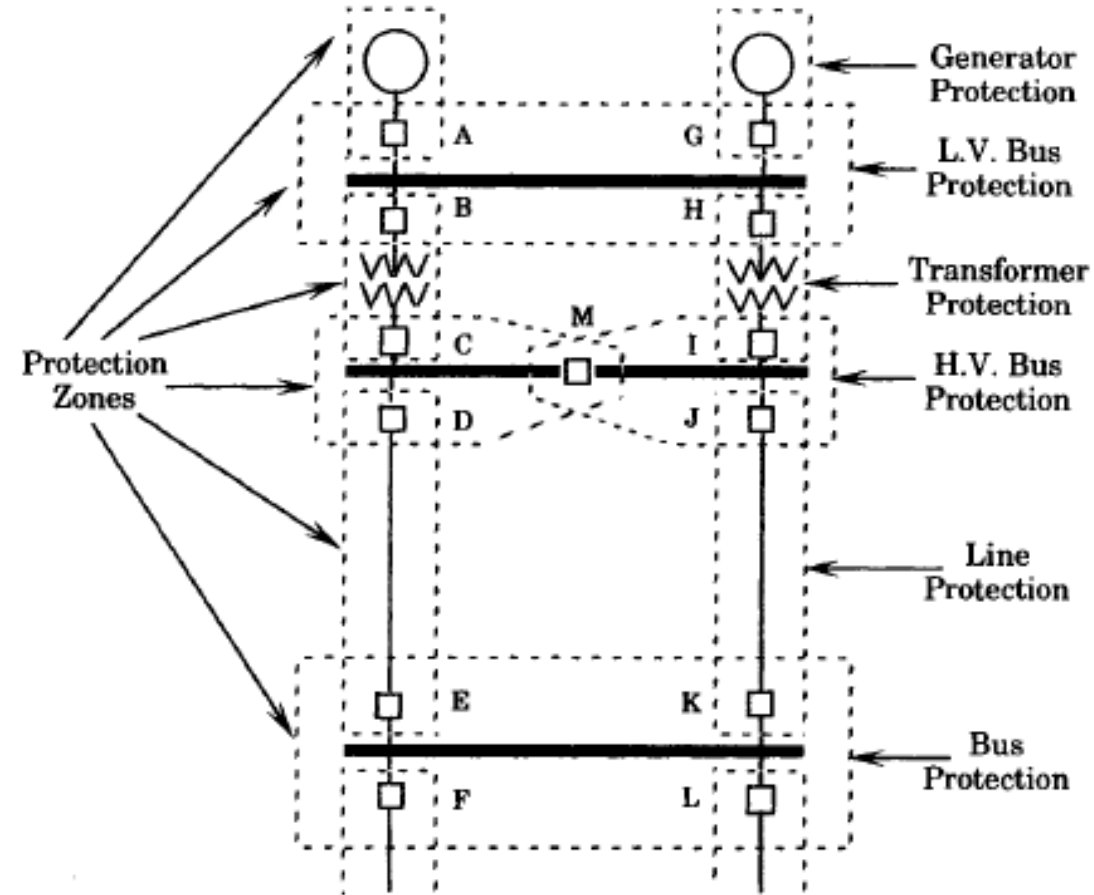

# DEFINITIONS USED IN SYSTEM PROTECTION

- ❑ **Undesired tripping (false tripping)** results when a relay trips unnecessarily for a fault outside its protection zone or when there is no fault at all. This can occur when the protective system is set with too high a sensitivity. Such operation may cause an unnecessary load outage, for example, on a radial circuit, or may cause overloading of adjacent lines of a network. Thus, in some cases, unnecessary tripping is merely an inconvenience, which, although undesirable, may not cause serious damage or overloading. In other cases, where an important line is falsely tripped, it can lead to cascading outages and very serious consequences.
- ❑ **Failure to trip** is a protective system malfunction in which the protective system fails to take appropriate action when a condition exists for which action is required. This type of failure may result in extensive damage to the faulted component if not rectified by backup protection.

# EXAMPLE: IMPACT OF DG ON PROTECTION SYSTEM

- Exceeding the Minimum and Maximum Fault Current Values; Impact on Breaking Capacity of Protection Devices.

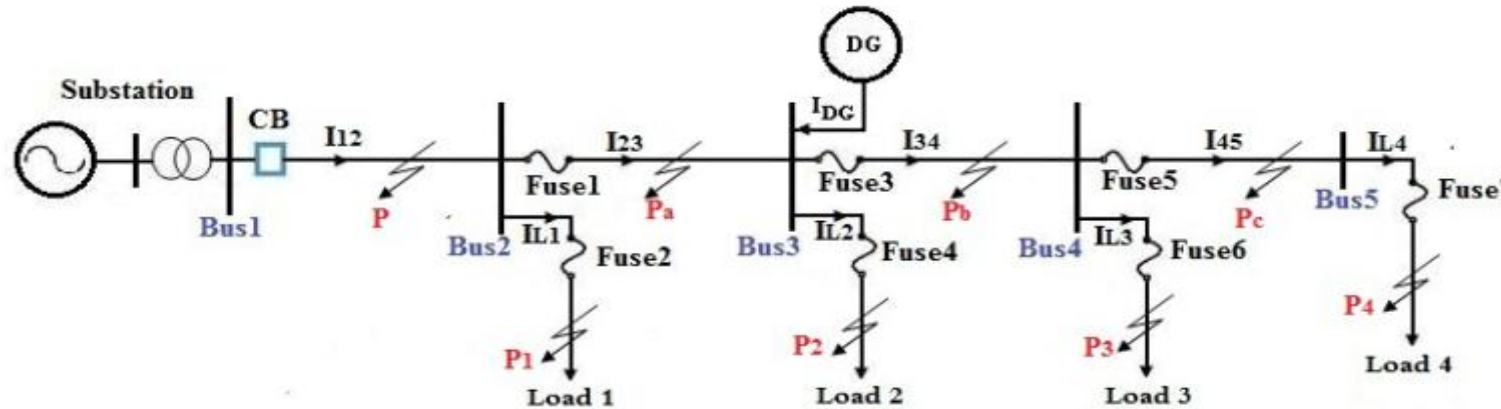

If a fault occurs at point P3:

*Without DG:* ( $I_{CB}=I_{F1}=I_{F3}=I_{F6}=I_{Fault} = I_S$ )

*With DG:* ( $I_{CB}=I_{F1}=I_S$ ), and ( $I_{F3}= I_{F6}= I_{Fault} = I_S+ I_{DG}$ )

However,

$(I_{F3}= I_{F6})_{WithDG} > (I_{F3}= I_{F6})_{WithoutDG}$

# EXAMPLE: IMPACT OF DG ON PROTECTION SYSTEM

## □ Mis-coordination of Protection Devices

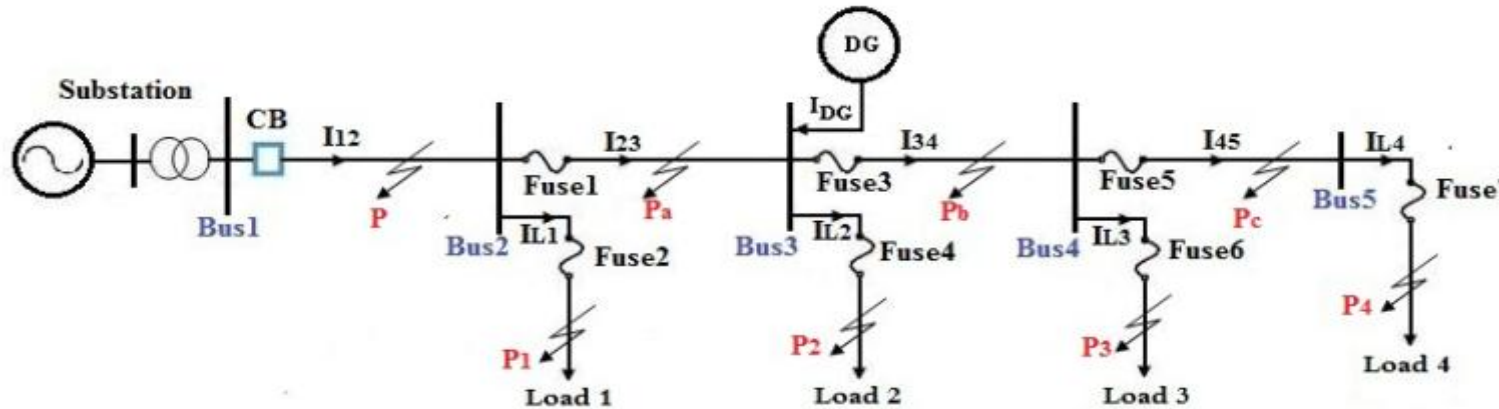

For coordination between Fuse 3 and Fuse 6, Fuse 6 should operate before Fuse 3; this requires that Total Clearing (TC) time curve of Fuse 6 is below the Minimum Melting (MM) time characteristic of Fuse 3 by a safe margin for any fault at position P<sub>3</sub>. As shown in Figure the fuses are coordinated for all fault currents below  $I_{Fmax}$ . After installing DG, ( $I_{F3} = I_{F6} = I_{Fault} = I_s + I_{DG2}$ ), it is possible that the fault current level exceeds  $I_{Fmax}$  and the coordination between these two fuses is lost

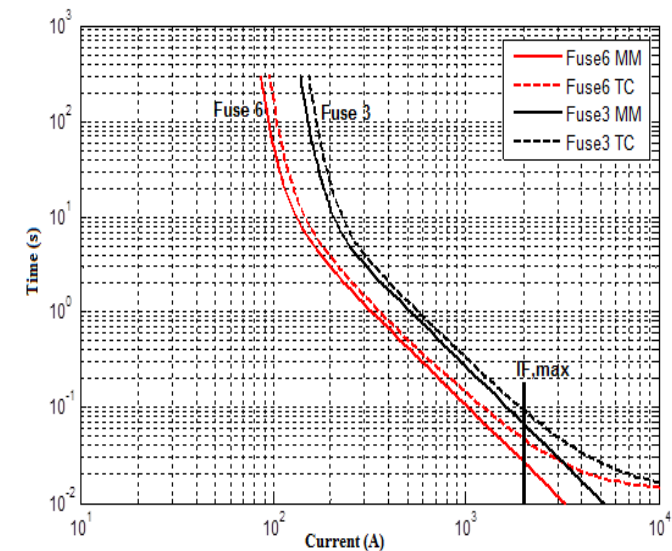

# EXAMPLE: IMPACT OF DG ON PROTECTION SYSTEM

## ❑ False Tripping of Feeders

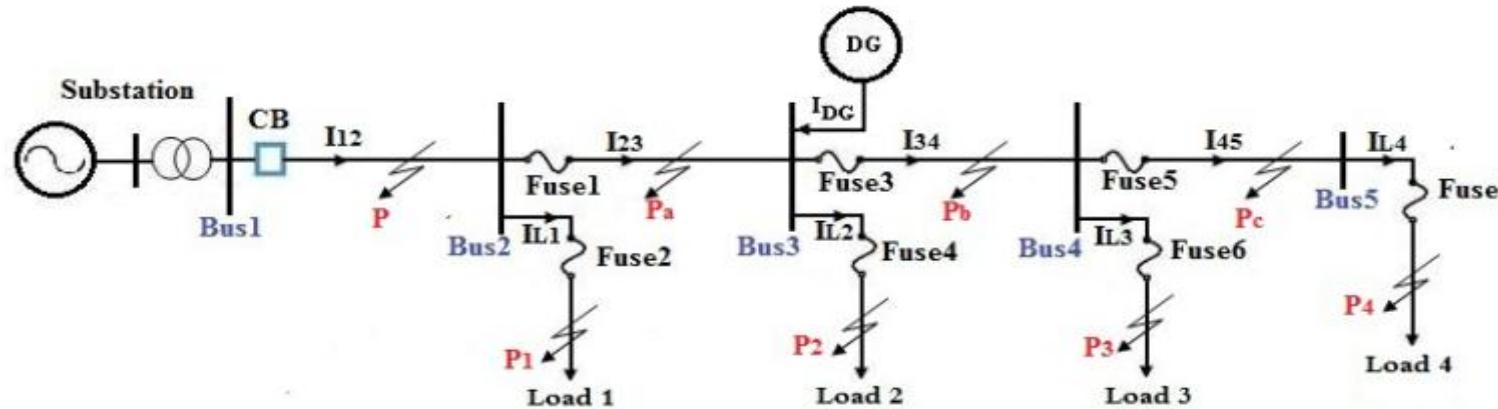

When a fault occurs at another feeder, the operating device located in that faulted feeder should operate. Nevertheless, the fuse at the feeder of the DG may operate and cause unreasonable electricity interruption. As an example; consider the network shown in Figure. The short-circuit fault occurs on position P1. Fuse 2 must operate to remove fault from network, but also Fuse 1 may be tripped because of over-current fed by the DG unit.



# EXAMPLE: IMPACT OF DG ON PROTECTION SYSTEM

## □ Relay Blindness Operation

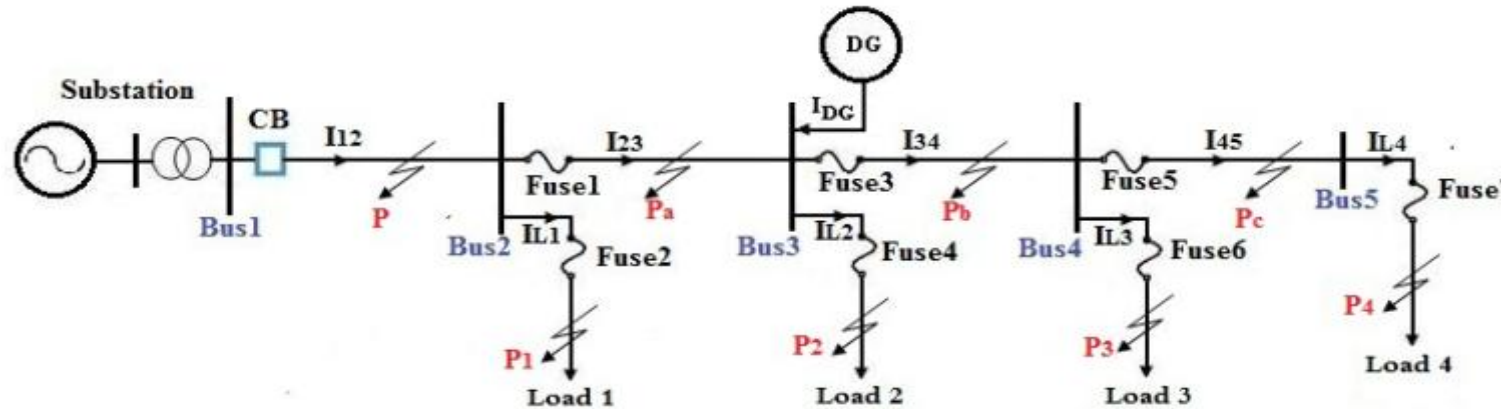

For correct operation of relay it is important that the relay measures the real fault current. As an example, assuming a short circuit at point  $P_b$ , the DG and substation generator contribute to the total fault current ( $I_{\text{Fault}} = I_s + I_{\text{DG}}$ ), but the relay will only measure the current coming from the substation ( $I_{\text{CB}} = I_s$ ). So, the relay detects only a part of the real fault current and may not operate properly.

# *The End of Introduction*

*Thanks For Your Attention*

*Grazie Per L'Attenzione*

شكراً لإنتباهكم

